

Newsletter
April '07

Assembly Rivets:

Two styles to choose from:

Push-Lok Rivet

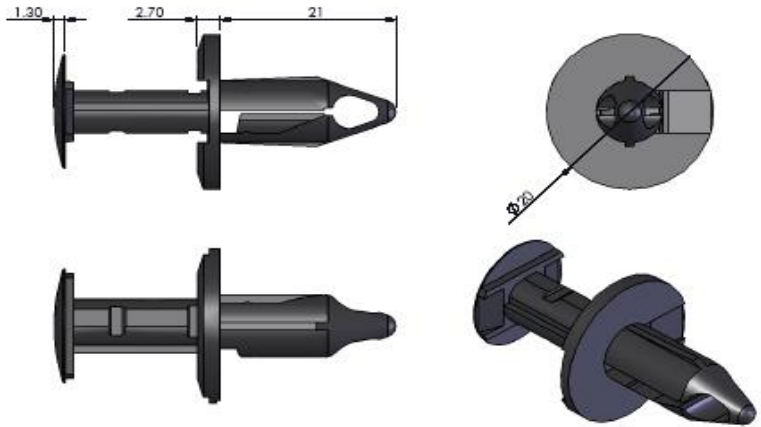

PART No.	HOLE SIZE	PANEL RANGE		SHOULDER HEIGHT	HEAD HEIGHT	HEAD DIA	LENGTH
		MIN	MAX				
TF0405196	Ø6.0	3.0	8.0	2.7	1.3	20.0	21.0

This easy to use Push-Lok Rivet is aimed at high volume manufacturing applications. The product has 2 positions pre & post assembly which have featured locking sections to ensure good transit protection & final panel retention.

The standard range of Tech-Fast panel fasteners is one of the most comprehensive available.

Tech-Fast.Com Limited

Specialises in the design & supply of technical plastic fasteners, closures & components. The company is active in all major global markets.

Web-site: www.tech-fast.com

Tech-Fast.Com Limited
Greenbank
High Lane
Salterforth
Lancashire
BB18 5SL



T: +44 (0) 1282 850001
F: +44 (0) 1282 850003
E: sales@tech-fast.com
W: www.tech-fast.com

Newsletter
April '07

Assembly Rivets:

Two styles to choose from:

Scrivet (6 legged)

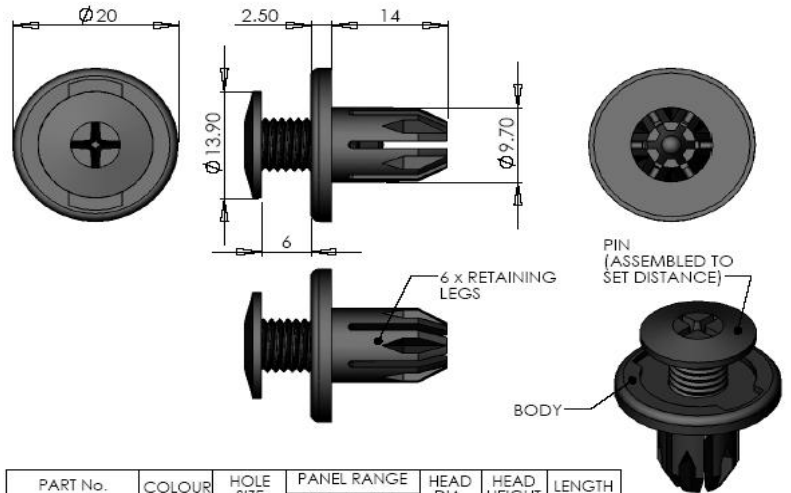

PART No.	COLOUR	HOLE SIZE	PANEL RANGE		HEAD DIA.	HEAD HEIGHT	LENGTH
			MIN	MAX			
TF0405160	BLACK	Ø10.0	6.0	9.0	Ø20.0	2.5	14.0
TF0405161	BLACK	Ø10.0	6.0	9.0	Ø20.0	2.5	14.0

The 6 legged Scrivet product has significant advantage where very high panel retention is required. This is due to the design having 6 legs & therefore a much higher contact area in the hole, also each leg has 2 crush ribs which form around the primary panel upon insertion & finally the male pin can be moulded in either PA66 for standard mounting or Glass Filled PP for maximum panel retention.

Tech-Fast.Com Limited

Specialises in the design & supply of technical plastic fasteners, closures & components. The company is active in all major global markets.

Web-site: www.tech-fast.com

Tech-Fast.Com Limited
Greenbank
High Lane
Salterforth
Lancashire
BB18 5SL

T: +44 (0) 1282 850001
F: +44 (0) 1282 850003
E: sales@tech-fast.com
W: www.tech-fast.com

